

**EJE 1:** PK 0+000 - 0+120  
 PK 0+155 - 0+264,130

**EJE 2:** PK 0+000 - 0+205  
 PK 0+240 - 0+280  
 PK 0+320 - 0+440

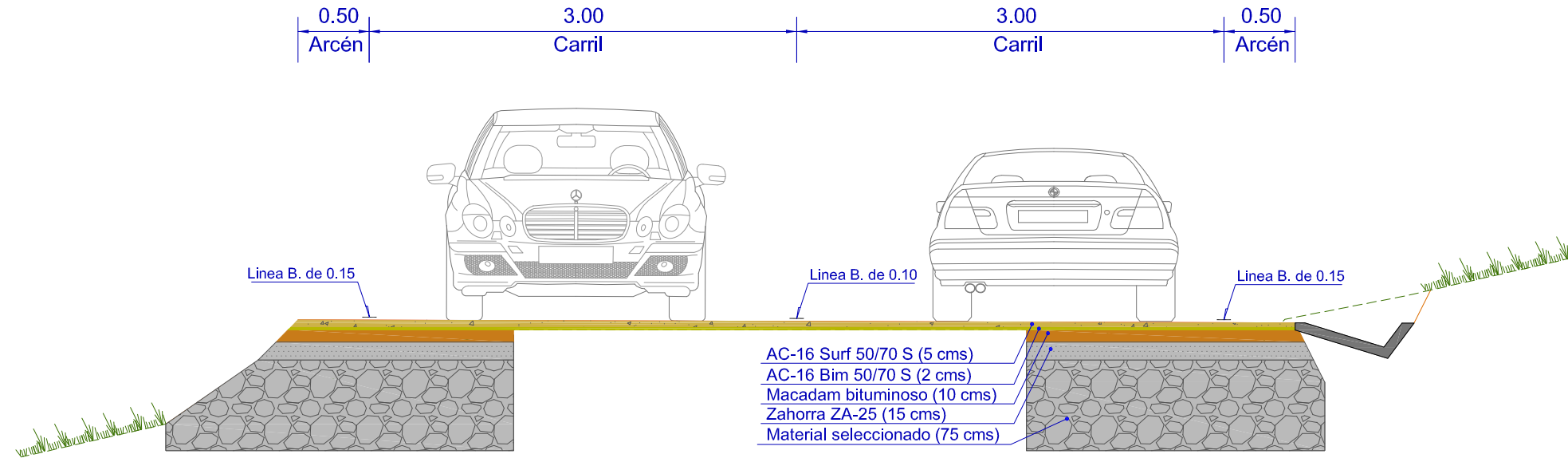

**EJE 1:** PK 0+120 - 0+155

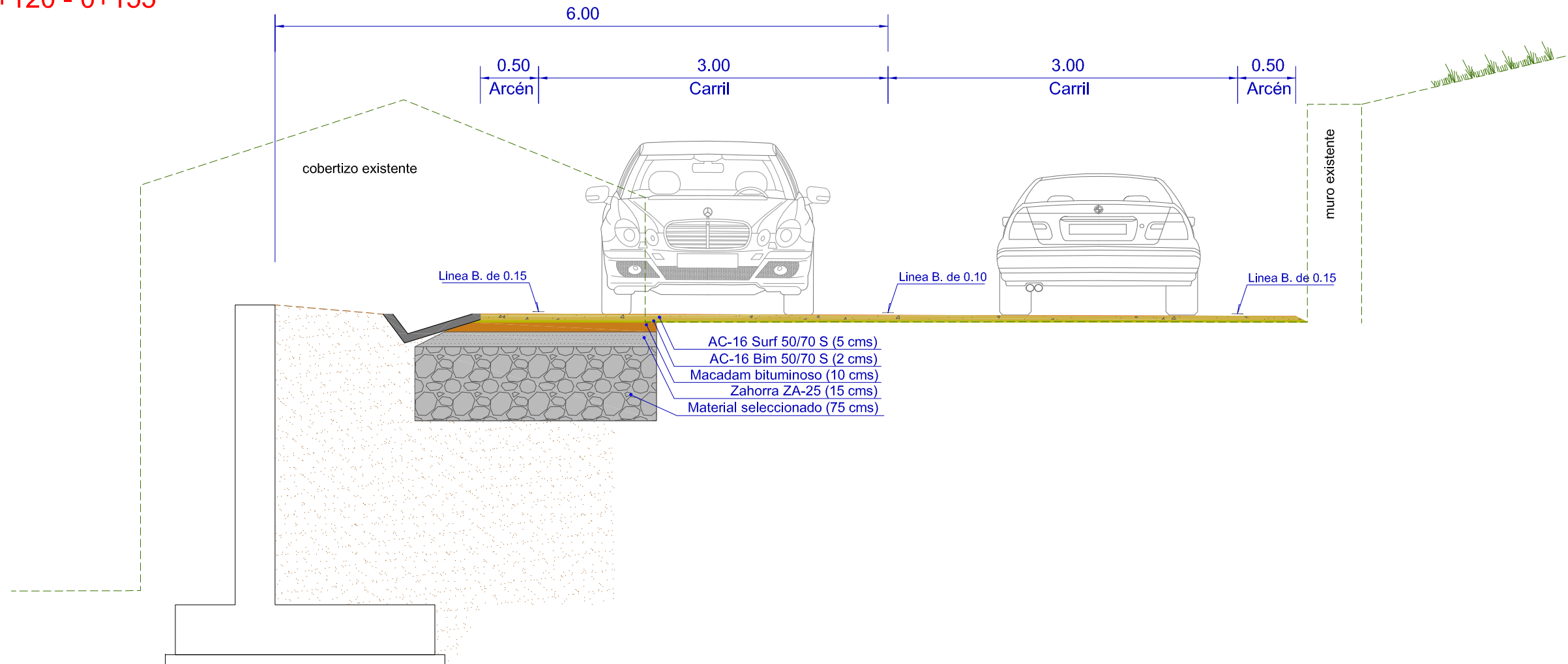

**EJE 2:** PK 0+205 - 0+240  
PK 0+280 - 0+320

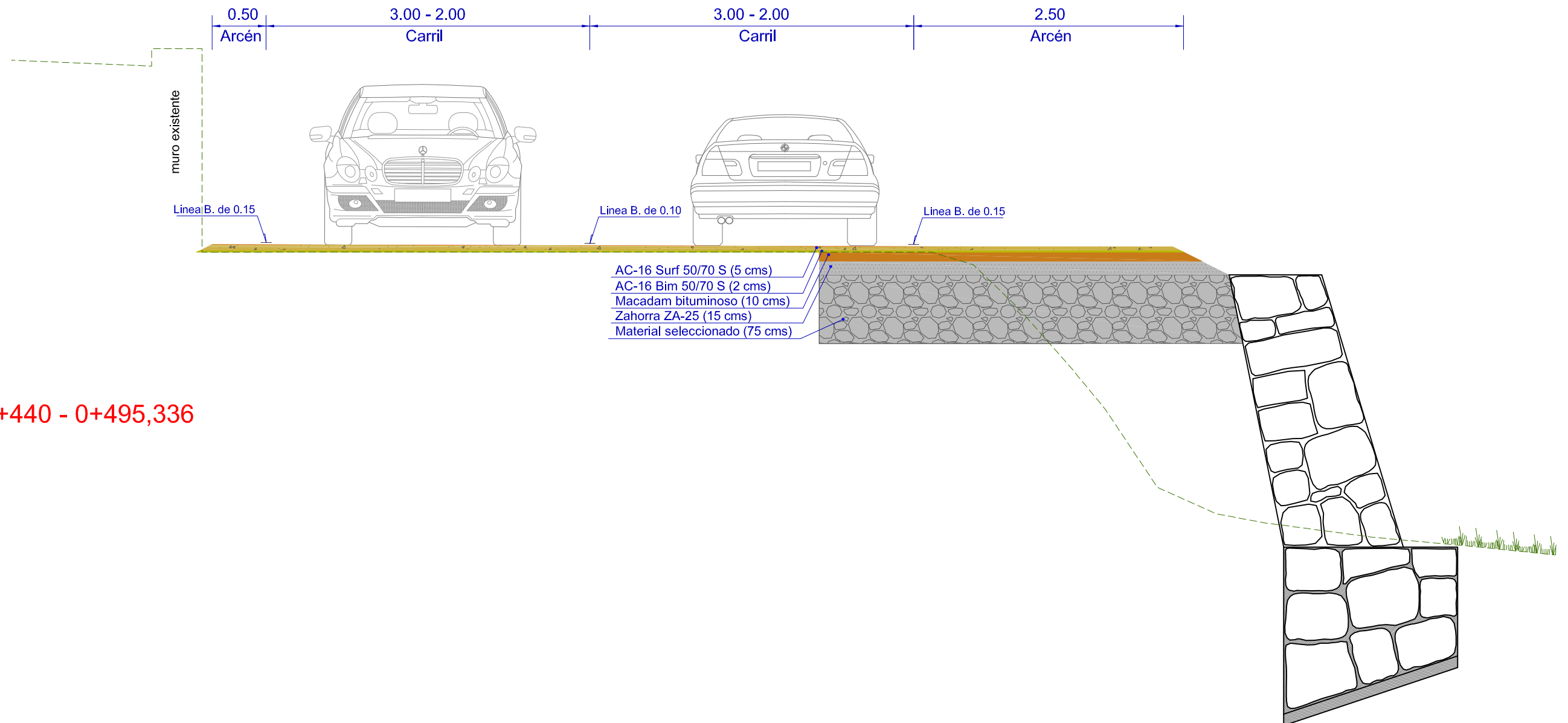
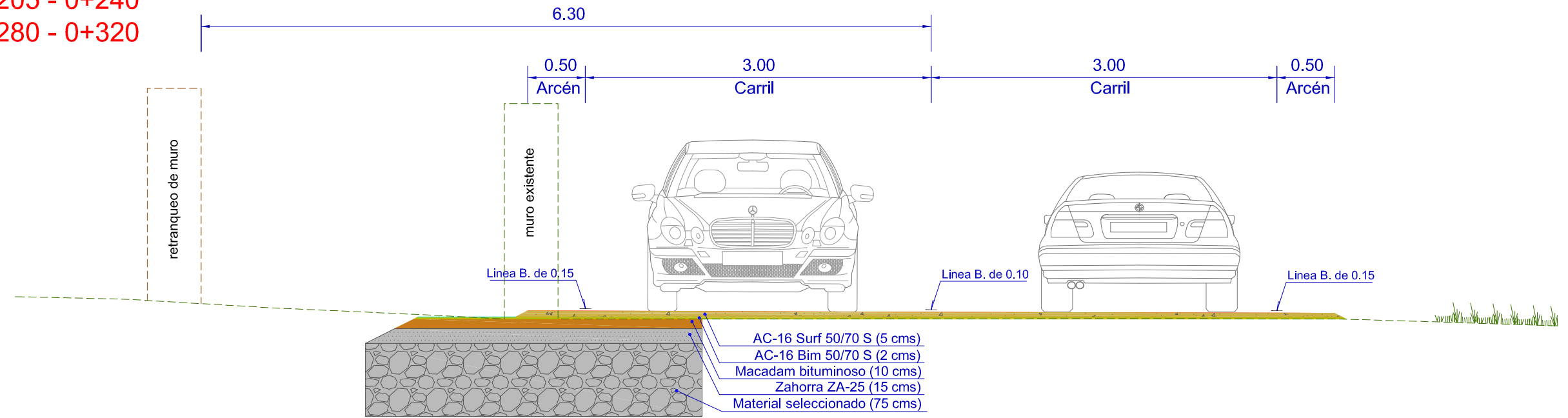

**EJE 2:** PK 0+440 - 0+495,336